

NOTES:

- 1-POLE TYPE: STRAIGHT SQUARE ANCHOR BASE
- 2-FINISH: SMOOTH BRONZE
- 3-MATERIAL: FIBERGLASS REINFORCED COMPOSITE EXCEPT AS NOTED
- 4-WEIGHT: 164 lbs

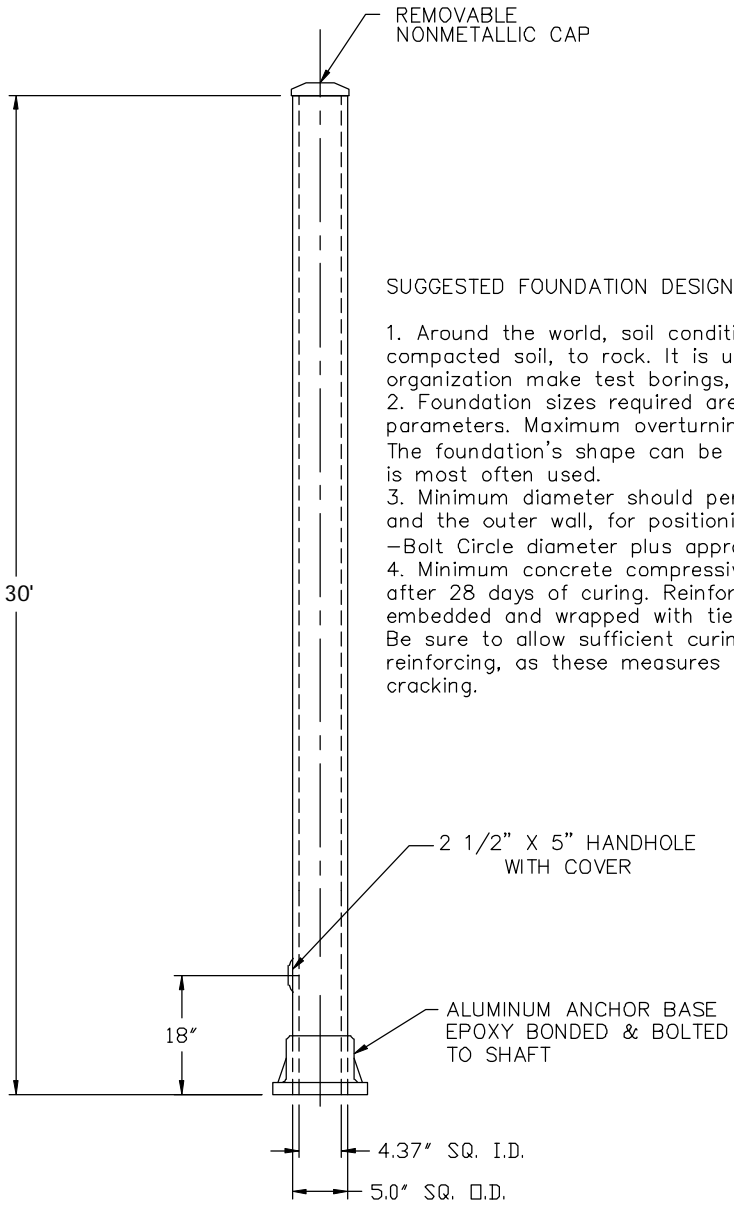

SUGGESTED FOUNDATION DESIGN

1. Around the world, soil conditions vary widely—from loose fill, to highly compacted soil, to rock. It is usually advisable to have a soil testing organization make test borings, since soil conditions cannot be predicted.
  2. Foundation sizes required are dependent on soil resistance and structure parameters. Maximum overturning moment for this pole series is 18,000 ft-lb. The foundation's shape can be round or square. A round cylindrical foundation is most often used.
  3. Minimum diameter should permit enough space, between the bolt circle and the outer wall, for positioning steel rebars and enclosing bolt hooks —Bolt Circle diameter plus approximately 12".
  4. Minimum concrete compressive strength should be approximately 3000 psi after 28 days of curing. Reinforcing bars should be deformed steel, vertically embedded and wrapped with tie wire.
- Be sure to allow sufficient curing time and provide adequate steel reinforcing, as these measures will greatly reduce the likelihood of concrete cracking.

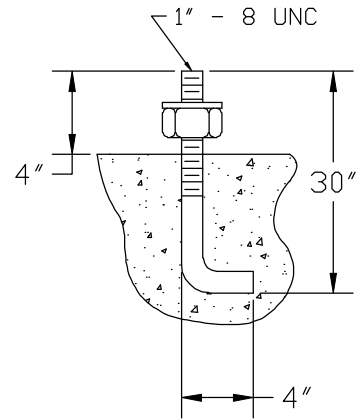
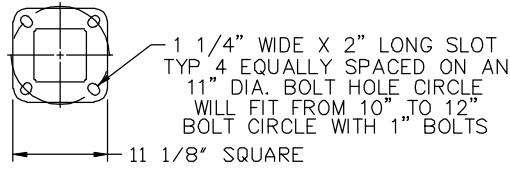

**BOLT DETAIL**

NOTE: IF LEVELING NUTS ARE NOT USED BOLT PROJECTION MUST BE 3" INSTEAD OF 4".

LET	WAS	BY	DATE

DESCRIPTION:

COMPOSITE STRAIGHT SQUARE, ANCHOR BASE  
5" x 5", SMOOTH BRONZE, CAPPED TOP



DRAWN:    CHK'D:    SCALE:    DATE:

SAVED AS:

PC. NO.

**AR30-BZQS**