

# Shakespeare Composite Structures

Shakespeare Composite Structures is a Philips group brand.  
19845 U.S. Highway 76, Newberry, SC 29108  
803.276.5504 · 800.800.9008 · f/ 803.276.8940  
[www.skp-cs.com](http://www.skp-cs.com)

Shakespeare Composite Structures · Decorative Pole Products

# Shakespeare Composite Structures

*Decorative Pole Products*

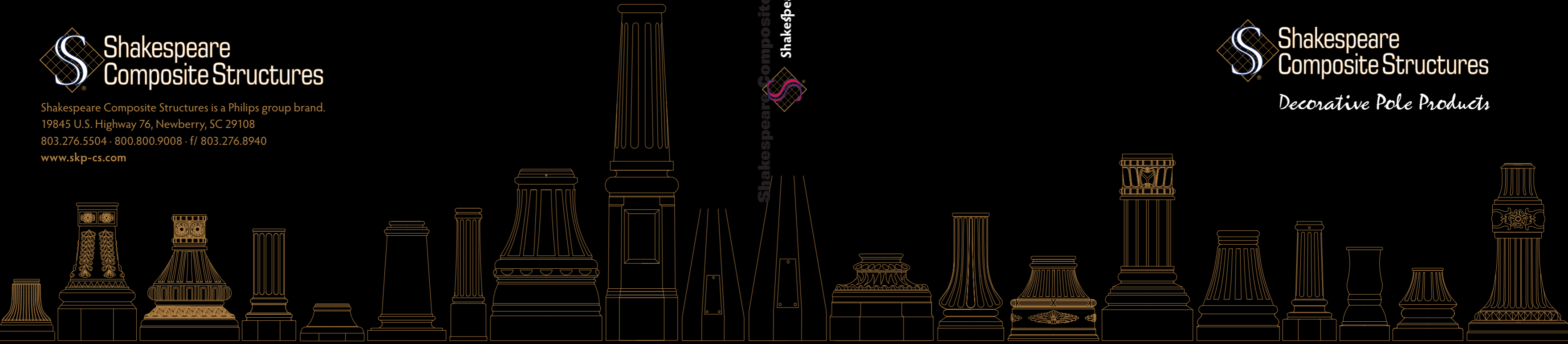



## Decorative Pole Products



## Table of Contents

Performance and Testing Addendum for Sample Specification	3
<b>Decorative Composite Tuff-Poles®</b>	
Historical Series	5-52
Polymer Concrete Series	53
Citiscapc Series (non-tapered shafts)	55-60
Streetscapc Series (tapered shafts)	61-72
<b>Decorative Arms and Brackets</b>	73
<b>Composite Shrouds</b>	77
One-Piece Shrouds	79-104
Two-Piece Shrouds	107-120

19845 U.S. Highway 76, Newberry, SC 29108  
 803.276.5504 · 800.800.9008 · f/803.276.8940  
 sales@skp-cs.com · [www.skp-cs.com](http://www.skp-cs.com)

# Composite Twin-fixture Arms

## DCTW

Catalog number:

**DCTW**

Material: Fiberglass reinforced composite (specify color)

Weight: 70 lbs.

EPA: 5.3 sq. ft.

Requires: 3" O.D. x 6" tall tenon

Standard, special, premium, and architectural colors available, or any color can be matched

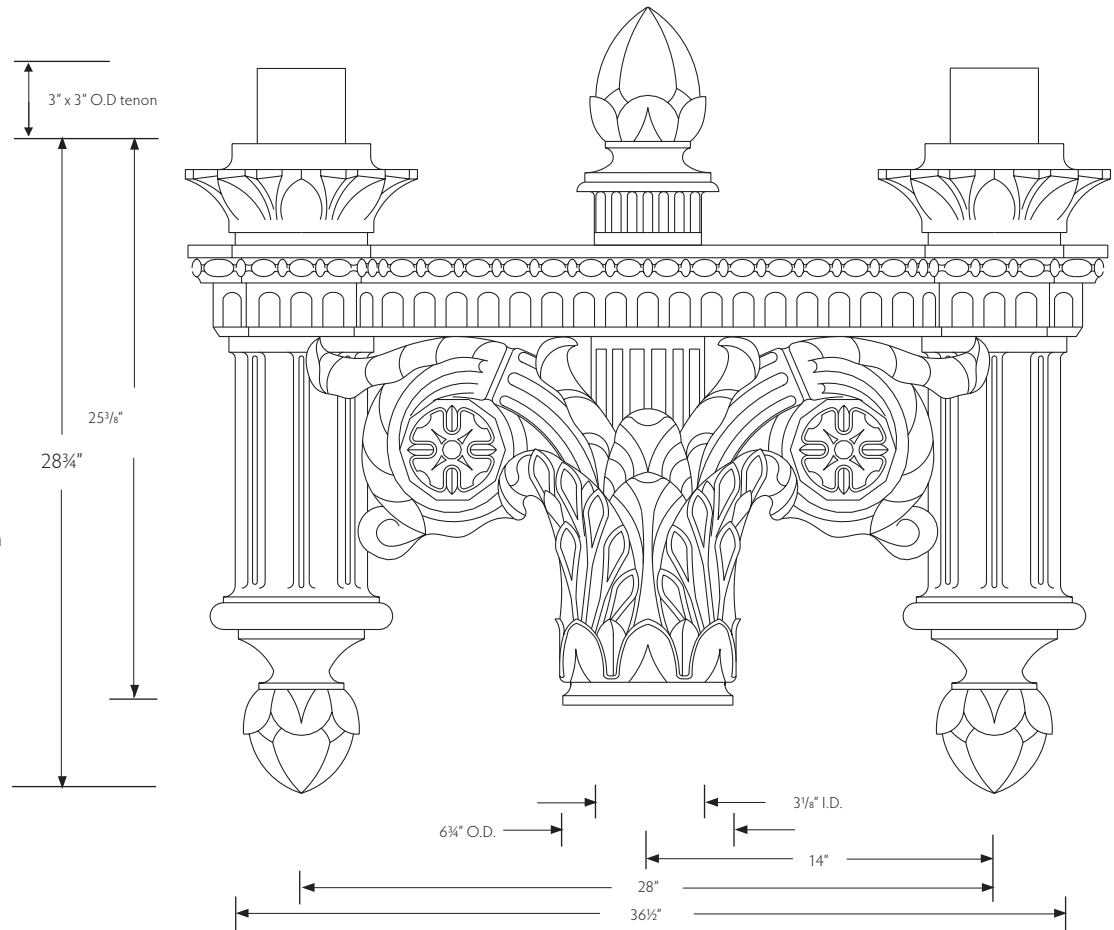

## Distinctive, classical beauty

Virtually maintenance free,  
fiberglass reinforced composite

One-piece construction

Standard or custom finishes and  
colors to match poles

Standard 3" x 3" dia. aluminum  
tenons for luminaire mounting



Washington, DC, historic district:  
Shakespeare Composite Structures™ D.C.  
Style Tuff-Pole® with DCTW Twin-fixture  
Decorative arm and Shakespeare's Style  
FAA composite luminaires.

# SCTW

## Shakespeare Composite Structures Composite Twin-fixture Arm

All dimensions and specifications nominal, and subject to change without notice or obligation. Please contact factory before site preparation begins.

Catalog number:

**SCTW**

Material: Fiberglass reinforced composite (specify color)

Weight: 40 lbs.

EPA: 4.3 sq. ft.

Requires: 3" O.D. x 6" tall tenon

Standard, special, premium, and architectural colors available, or any color can be matched

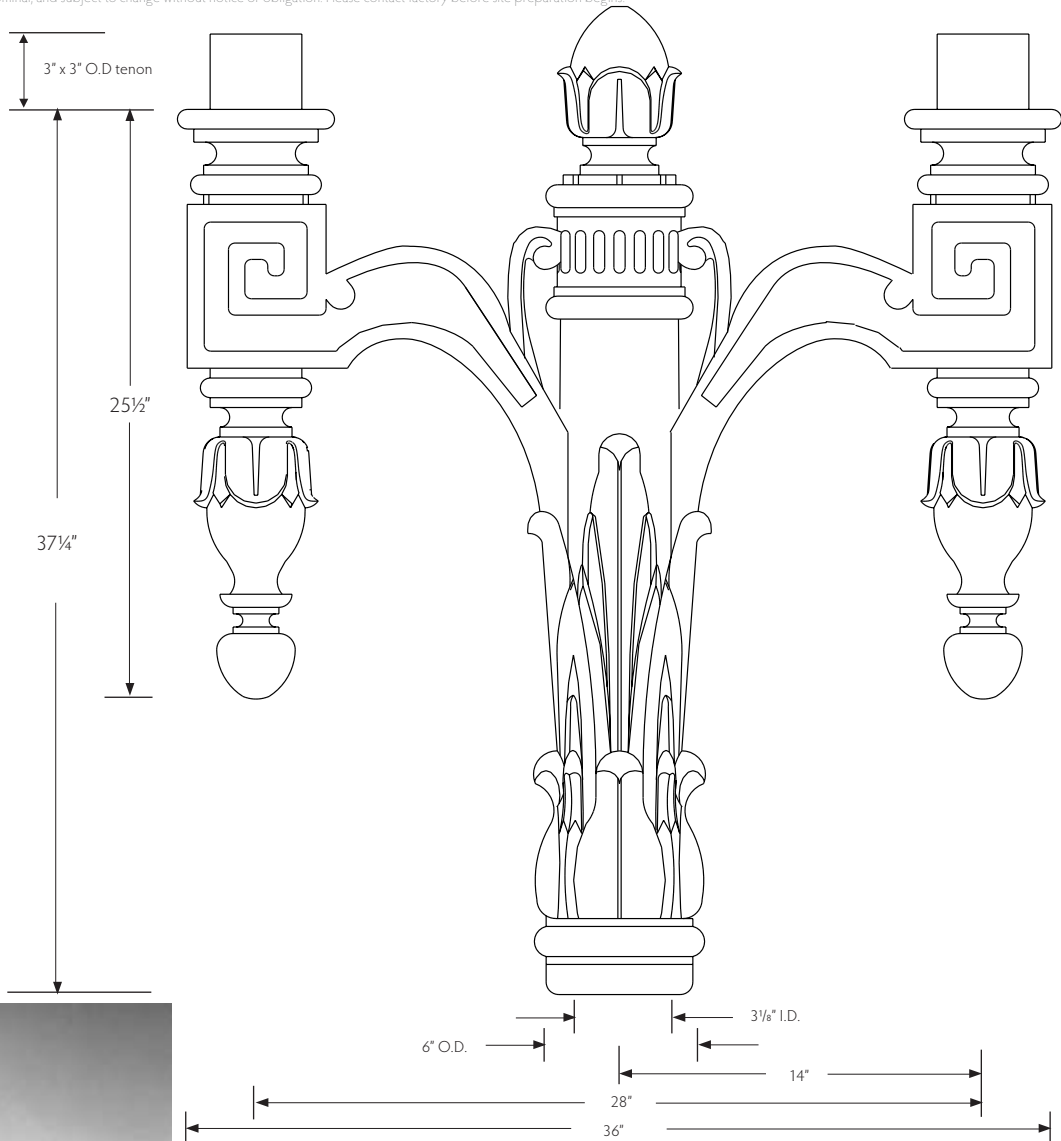

These decorative arms look great with fluted or smooth shafts on Shakespeare Composite Structures D.C., San Gabriel, and Washington style Tuff-Poles®.

Washington Style pole with SCTW Twin-fixture Decorative Twin Arm and two acorn luminaires



San Gabriel Style Tuff-Pole® with SCTW Twin-fixture Decorative Twin Arm and acorn luminaires



# Decorative Arms Aluminum

## Decorative Single- or Double-Fixture Arm Tenon mounted, 4', 6' or 8' arms

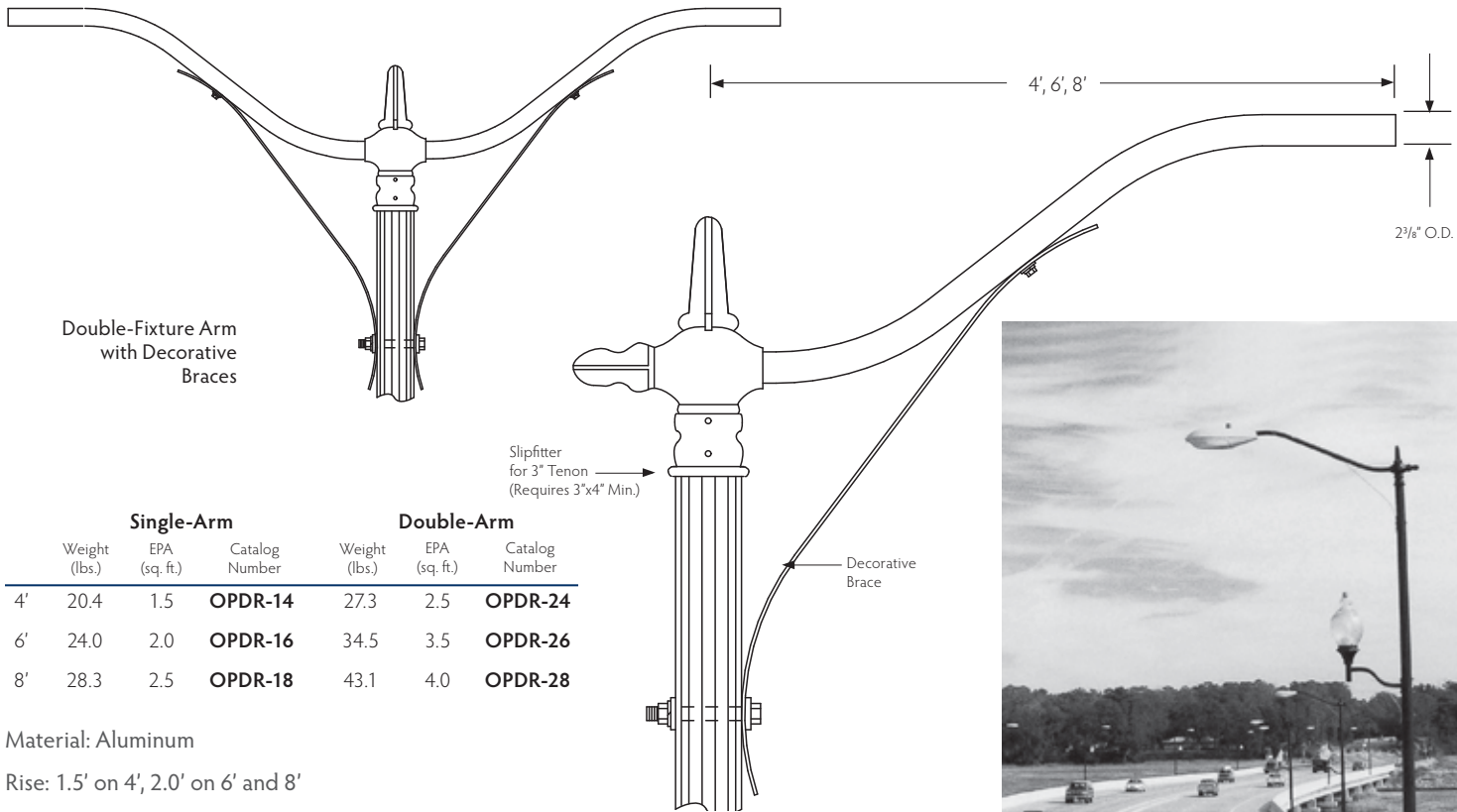

Double-Fixture Arm with Decorative Braces

**Single-Arm**

**Double-Arm**

	Weight (lbs.)	EPA (sq. ft.)	Catalog Number	Weight (lbs.)	EPA (sq. ft.)	Catalog Number
4'	20.4	1.5	<b>OPDR-14</b>	27.3	2.5	<b>OPDR-24</b>
6'	24.0	2.0	<b>OPDR-16</b>	34.5	3.5	<b>OPDR-26</b>
8'	28.3	2.5	<b>OPDR-18</b>	43.1	4.0	<b>OPDR-28</b>

Material: Aluminum

Rise: 1.5' on 4', 2.0' on 6' and 8'

Requires: 3" O.D. X 4" Min. to 6" max. Length tenon



## A-30 Decorative Twin-Fixture Arm Tenon mounted

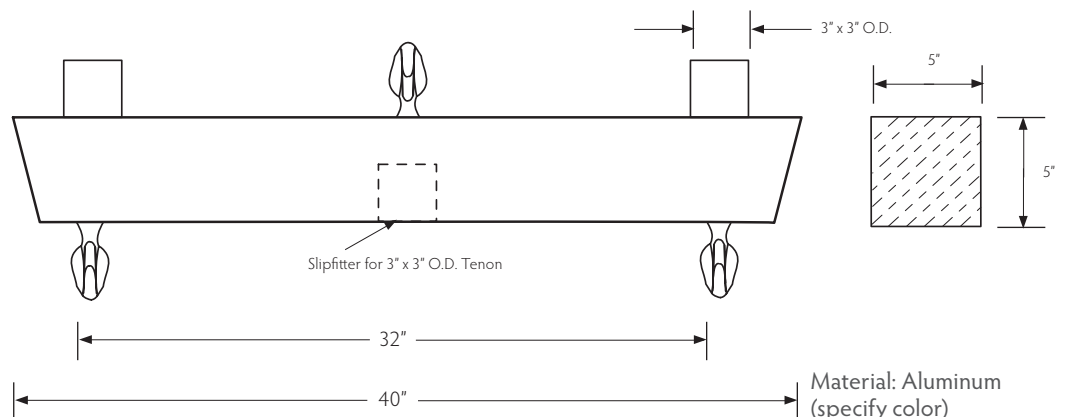

Material: Aluminum (specify color)

Weight: 16 lbs.

EPA: 2.0 Sq. Ft.

Catalog Number: A-30



# Decorative Brackets

## Aluminum

All dimensions and specifications nominal, and subject to change without notice or obligation. Please contact factory before site preparation begins.

### OPAR-1.5-30S Decorative Side Bracket

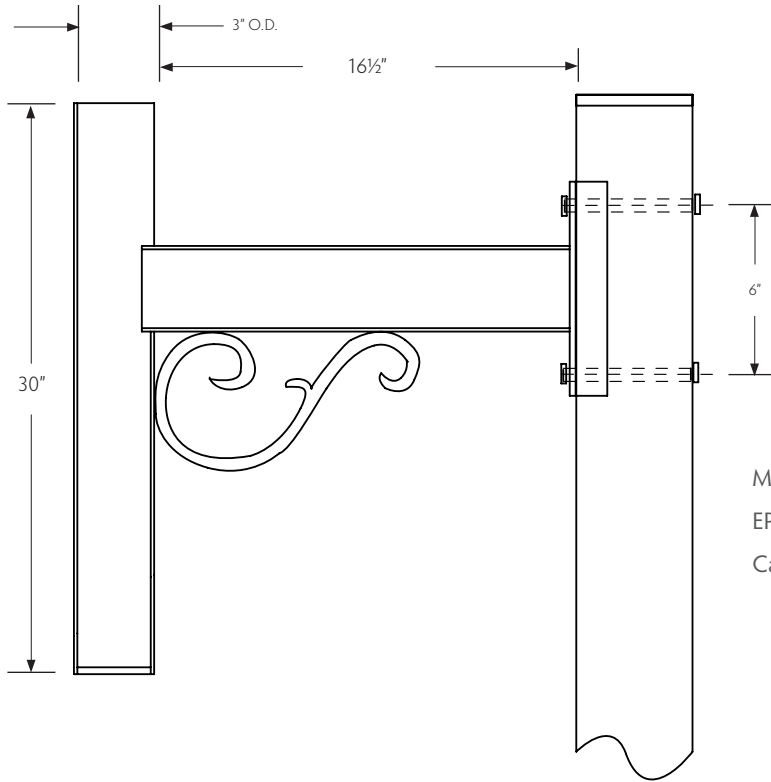

Material: Aluminum (specify color)  
 EPA: 1.3 sq. ft.  
 Catalog Number: **OPAR-1.5-30S**

### OPAR-1.5-30S Decorative Side Bracket

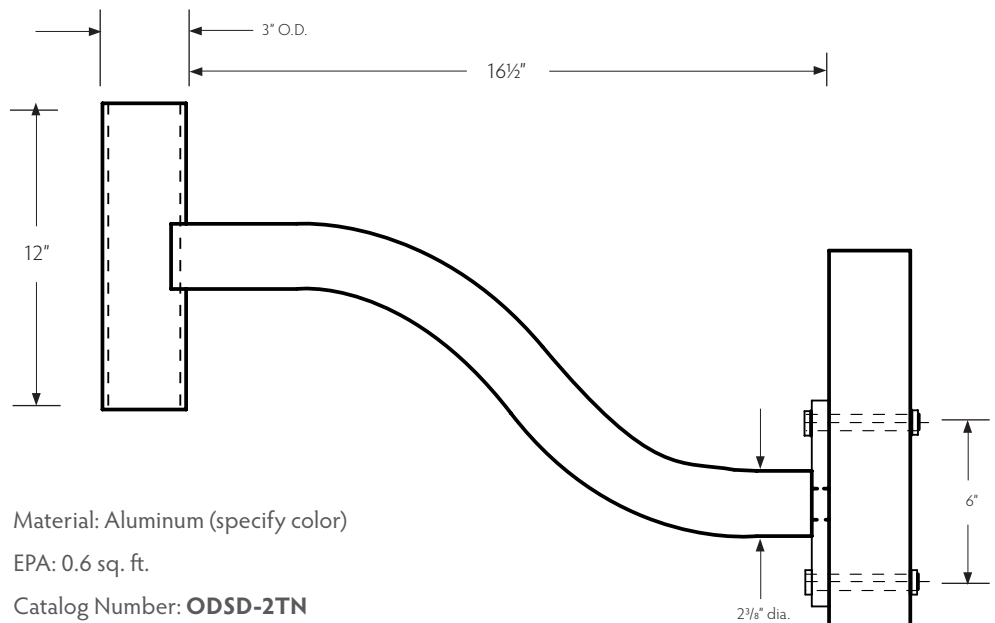

Material: Aluminum (specify color)  
 EPA: 0.6 sq. ft.  
 Catalog Number: **ODSD-2TN**

